

Investigating 6 degree-of-freedom loading on shallow foundations

B.W. Byrne & G.T. Houlsby

Department of Engineering Science, University of Oxford, United Kingdom

ABSTRACT: Previous laboratory studies of the response of shallow foundations have only considered planar loading. This paper describes the development of a loading device capable of applying general loading on model shallow foundations. Loading involving all six degrees of freedom {vertical (V), horizontal (H_2, H_3), torsion (Q) and overturning moment (M_2, M_3)}, can be applied experimentally to the model foundations. Aspects of the design, including the loading rig configuration, development of a six degree-of-freedom load cell, numerical control algorithms and an accurate displacement measuring system are described. Finally results from initial experiments are presented that provide evidence for the generalisation of existing work-hardening plasticity models from planar loading to the general loading condition.

1 INTRODUCTION

1.1 Motivation

The response of shallow foundations subjected to general loading is an important area of civil engineering, particularly in the offshore industry, where foundations must be designed for loadings due to harsh environmental conditions. These conditions may lead to large vertical (V), horizontal (H) and moment (M) loads on the foundations. Whilst earlier studies considered overall stability, more recent studies have attempted to model the displacements, using model tests to calibrate work hardening plasticity theories (Houlsby et al. 1999, Martin & Houlsby 2000, 2001, Byrne & Houlsby 2001, Cassidy et al. 2002, Houlsby & Cassidy 2002).

Recently, this work has focussed on suction caisson foundations (Byrne et al. 2002, Byrne & Houlsby 2003). With geometry rather like an upturned bucket, the caisson is simply installed by sucking the water out, and thus forcing the skirts into the seabed. This type of foundation has potential applications in the developing offshore wind energy industry. In this application the loading consists of very high moment and horizontal loads, but low vertical loads. This is a very different pattern of loading from that experienced by heavier structures in the oil and gas sector. In addition, the wind and wave directions may not coincide, so the base shear and moment are not in the same direction. Considerable uncertainty surrounds how these foundations may perform under these loading conditions (Byrne & Houlsby 2003).

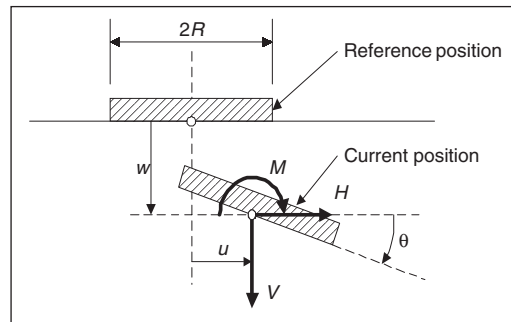

Figure 1. Sign conventions for 3 degree-of-freedom loading (Butterfield et al. 1997).

1.2 Background theory

Figure 1 shows a shallow foundation under three degree-of-freedom loading as defined by Butterfield et al. (1997). This problem has received much attention over the past twenty years, and the load displacement behaviour of the foundation can be captured well by work-hardening plasticity theories (as shown by the papers cited above). A key component of the plasticity theories is the definition of a suitable yield surface. Figure 2 shows the shape of a yield surface that has been defined experimentally, for shallow foundations under three degree-of-freedom loading. This shape can be expressed mathematically as equation 1.

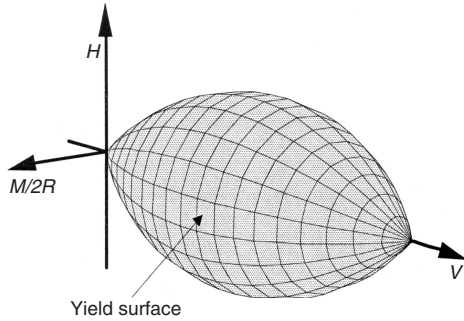

Figure 2. Yield surface for shallow foundations.

$$f = \left(\frac{h}{h_o}\right)^2 + \left(\frac{m}{m_o}\right)^2 - 2a \frac{h}{h_o} \frac{m}{m_o} - \beta_{12} v^{2\beta_1} (1-v)^{2\beta_2} = 0 \quad (1)$$

where $v = V/V_o$, $m = M/2RV_o$, $h = H/V_o$, h_o is the normalised horizontal load capacity, m_o is the normalised moment capacity, a is the eccentricity of the

ellipse in the $h:m$ plane, $\beta_{12} = \left(\frac{(\beta_1 + \beta_2)^{(\beta_1 + \beta_2)}}{\beta_1^{\beta_1} \beta_2^{\beta_2}}\right)^2$

and β_1 and β_2 are shaping parameters for the section in the vertical load plane. Numerous studies have identified the parameter values for the yield surface for a variety of footing types and for different soils – for example see Houlsby et al. (1999) for shallow circular foundations on sand, or Martin & Houlsby (2000) for spudcans on clay. A natural extension of these theories is to six degrees-of-freedom and Martin (1994) proposed an expression for this case:

$$f = \left(\frac{h_2}{h_o}\right)^2 + \left(\frac{h_3}{h_o}\right)^2 + \left(\frac{m_3}{m_o}\right)^2 + \left(\frac{m_2}{m_o}\right)^2 + \left(\frac{q}{q_o}\right)^2 - 2a \left(\frac{h_3 m_2 - h_2 m_3}{h_o m_o}\right) - \beta_{12} v^{2\beta_1} (1-v)^{2\beta_2} = 0 \quad (2)$$

where $h_2 = H_2/V_o$, $h_3 = H_3/V_o$, $m_2 = M_2/2RV_o$, $m_3 = M_3/2RV_o$ and $q = Q/2RV_o$. Figure 3 shows the definitions of the loads from Butterfield et al. (1997). The displacements work-conjugate to the loads (V , H_2 , H_3 , Q , M_2 , M_3) are (w , u_2 , u_3 , ω , θ_2 , θ_3). There has been no systematic study of footing response to full six degree-of-freedom loading to verify the extension of the planar loading theories to the general case. In the following the development of a loading device capable of applying the general loading is discussed, and some initial experimental results are presented that can be used to verify equation 2.

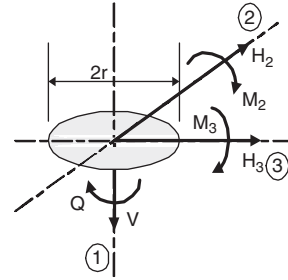

Figure 3. 6dof loading on a circular foundation.

2 DESIGN OF A 6 D-O-F LOADING RIG

2.1 The loading system

Previous experimental work at Oxford has used a three degree-of-freedom (3dof) loading device designed by Martin (1994). This planar loading device achieves vertical and horizontal motion by using a system of sliding plates, and rotational motion by rotating the loading arm relative to these plates. All motions are independent of each other, and are each driven by a stepper motor – these features are useful for implementing load and displacement control systems. However, this type of system would become too cumbersome for six degree-of-freedom (6dof) motions, and so an alternative approach is required. Typically, in robotics applications, the Stewart Platform (Stewart 1965) is considered to be the most elegant approach to achieving 6dof movement of a platform. There are numerous applications of this system in robotics, but the authors do not believe the system has been used for the testing of civil engineering structures, and in particular testing of foundations. The arrangement described in this paper is a variant of the Stewart platform, and similar arrangements are used, for instance, in the automobile industry for dynamic testing of vehicles.

The system uses six actuators which, at one end, are connected to the loading platform, and at the other are connected to a stiff reaction frame. Provided that six properly arranged actuators are used, and are pinned at both ends, then it is possible to achieve 6dof motion of the loading platform by changing the lengths of the actuators in a co-ordinated fashion. By careful selection of the actuator geometry, it is possible to ensure that the control problem is well-conditioned, so that calculations proceed in a straightforward fashion.

The disadvantage with the Stewart Platform is that the simple motions are not linearly or independently related to the motion of any individual actuator, unlike the 3dof system of Martin (1994). Therefore, quite complex control routines are required to ensure that all actuators move in concert to achieve the desired motion.

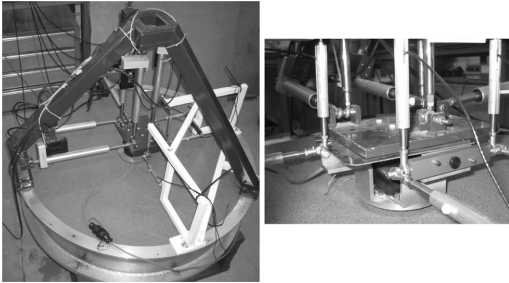

Figure 4. Photos of the 6dof loading rig including a close-up of the small LVDT measurement system.

Figure 4 shows the loading rig as constructed, showing three actuators approximately vertical and three actuators approximately horizontal. This arrangement ensures that the problem is well conditioned, as the main motions can be directly related to the motions of a sub-set of the actuators. For example, to achieve vertical movement the three vertical actuators must move the same distance, while only a slight adjustment of the horizontal actuators is required.

The actuators, supplied by Ultra Motion, are linear actuators each powered by an Animatics Smart Motor. This brushless DC servo-motor incorporates an integrated control system featuring a motion controller, encoder and amplifier. The actuators have a maximum extension of 200 mm and can move at rates of up to 5 mm/s. Commands to the actuators can specify relative motions, position, velocity or acceleration. The actuators are daisy-chained together and commands can be sent to individual actuators and then executed simultaneously with a global command. More importantly, a number of moves can be downloaded to on-board memory on the motors, and then executed according to a synchronised clock system common to all actuators. This makes it possible to execute complicated platform motions provided one can determine, in advance, a time history of the individual actuator motions required.

2.2 The control program

A program has been written in Visual Basic to control the loading system. The program allows input of a sequence of moves in terms of the motions (w , u_2 , u_3 , ω , θ_2 , θ_3) of the platform, known as the pose. These motions can be described in terms of a rotation and translation matrix (i.e. a transformation matrix). This matrix can be applied to the co-ordinates of the pinned connections of the actuators with the loading platform to produce a new set of co-ordinates for the platform in its new position. If the co-ordinates of the other (fixed) ends of the actuators are known, then it is possible to determine the required lengths of each actuator. To move the platform to the new position simply requires

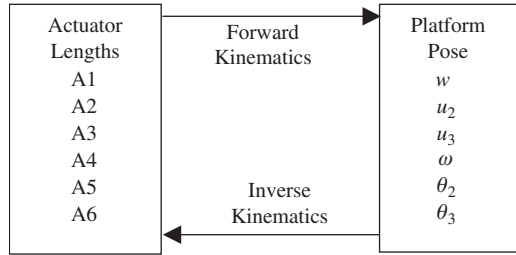

Figure 5. Calculation procedures used in computer program.

extending/retracting each actuator to its required length. This calculation procedure is known as the *inverse kinematics* problem and is a simple analytical calculation.

The opposite calculation, called the *forward kinematics* problem, is not so straightforward, and requires a numerical solution. If the lengths of each actuator are known, then it is possible to calculate the new pose of the platform. Within the actuators are linear potentiometers that allow the user to determine the current length of the actuator, and therefore the pose of the platform. Both inverse and forward kinematics procedures are used within the software as shown in Figure 5.

A typical test proceeds by determining the initial platform pose using the forward procedure. The user then specifies a sequence of moves in terms of platform pose. These moves are broken into a series of small moves so that the non-linearity of motion of each actuator can be captured. The inverse procedure is used to calculate for each of the moves the required length of each actuator. A file of actuator lengths with time (position-time data) is recorded. The relevant data from this file are sent to each actuator, and each movement is executed simultaneously. An on-board buffering system allows moves to be downloaded to each actuator. The actuators themselves use sophisticated control processes to determine the velocity and accelerations required, so that the actuator reaches each position at the time required, thereby ensuring a smooth motion.

While the moves are being performed the control program logs the data. In particular the actuator lengths are recorded and the platform pose is calculated and displayed.

2.3 The load cell

The load cell was constructed using a thin walled cylinder of radius $r = 27.5$ mm, wall thickness $t = 0.475$ mm and length 70 mm. It was fabricated from Aluminium alloy with a Young's Modulus of 72 GPa and a shear modulus of 27.1 GPa. The thin walled section was machined from a larger block, leaving heavy end flanges. The transition from thin-walled section to flange was smoothed at an appropriate radius to minimise stress concentrations. A total of 32 strain gauges



Figure 6. The 6 degree-of-freedom load cell.

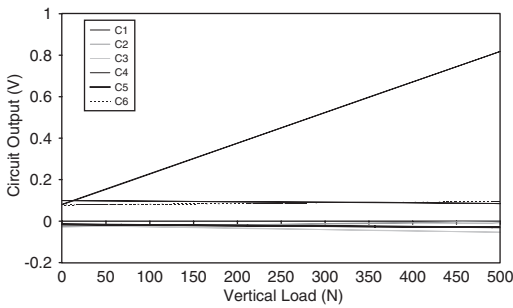

Figure 7. Calibration curves for the loadcell under vertical loading.

are fixed to the outer surface of the cylinder to measure the appropriate strains. Figure 6 shows the completed cell. The strain gauges were arranged in six Wheatstone bridge circuits, each corresponding to the measurement of a particular load component. Each circuit was fully compensated for temperature. Eight gauges were used for the vertical and torque circuits, and four gauges for the moment and horizontal load circuits. The cell was calibrated by applying known loads and measuring the output from all six circuits. By varying the loads one at a time, it is possible to determine components of the matrix \mathbf{X} relating loads to voltages in the equation $\mathbf{C} = \mathbf{X}\mathbf{F}$ where \mathbf{C} is the circuit output vector and \mathbf{F} is the load vector. Figure 7 shows the results from the six circuits for changes in the vertical load. The slopes for these six curves represent the components of the part of the matrix relating to vertical load (i.e. the first column of the matrix \mathbf{X}). Inverting \mathbf{X} produces a six by six calibration matrix that can be incorporated into the control program, so that loads are calculated during the experiment. Note that the design of the circuits is such that the off-diagonal terms are small. This is indicated in Figure 7 where only one circuit is responsive to the change in applied load.

2.4 Small LVDT system

One determination of the platform pose is by using the linear potentiometers within the actuators. This, however, provides only a coarse measurement of the platform pose. In particular there are issues of electrical noise and rig stiffness which have a significant impact on both the resolution and accuracy of this measurement. To achieve a more accurate determination of the foundation movement a system of small LVDTs (20 mm range) are used. These are placed in a similar configuration to the actuators, but supported on a separate frame as shown in Figure 4. The program carries out the forward kinematics calculation to determine the pose of the platform, given the measured lengths of the LVDTs. This allows very fine resolution of the foundation movement to the order of a few microns (Williams 2005).

3 EXPERIMENTAL RESULTS

Some preliminary experimental results on a 150 mm diameter flat circular footing using only displacement control are presented here. At the time of writing load control routines were being developed and are anticipated to be implemented in the near future. The experiments were carried out on Leighton Buzzard 14/25 silica sand. This is a uniform sand with particle sizes ranging from 0.6 mm to 1.18 mm. The maximum and minimum void ratios are 0.79 and 0.49 respectively. The sand was prepared in a loose state with a relative density estimated as 20%. Fuller details of the experimental work are reported by ap Gwilym (2004), Stiles (2004) and Williams (2005). The experiments were designed to determine the shape of the yield surface in the six dimensions. A number of ‘swipe tests’ were performed with various combinations of translations and rotations at a constant vertical displacement. The swipe test has been used extensively to determine the shape of yield surfaces, see Martin (1994), Gottardi et al. (1999), Martin & Houlsby (2000), Byrne & Houlsby (2001).

3.1 Vertical loading

Prior to carrying out the swipe tests it was necessary to perform vertical loading tests, as these give information for the hardening law. Five experiments are shown in Figure 8, showing good repeatability of the results. Note that the measurement of the displacement is coarse, as in these experiments the small LVDT system was not used.

3.2 Swipe tests

A number of swipe tests were performed to investigate the suitability of equation 2. A typical experimental

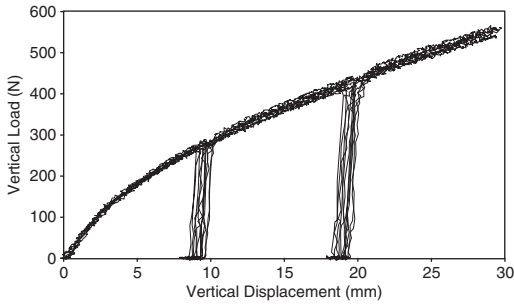

Figure 8. Typical vertical loading results.

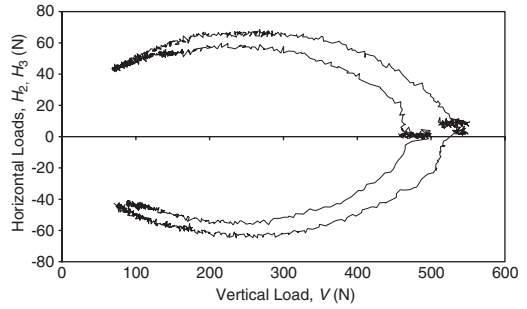

Figure 10. Horizontal swipe results.

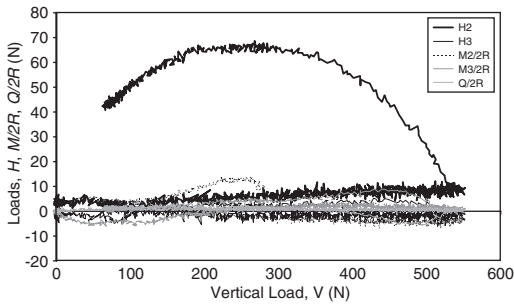

Figure 9. A horizontal swipe result.

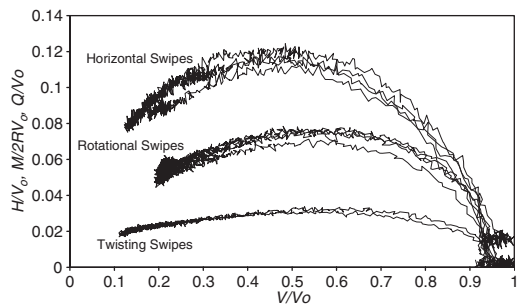

Figure 11. Results normalised by V_0 .

result for a swipe test is shown in Figure 9. In this test the footing was displaced vertically to a pre-specified distance at which point the vertical load reached approximately 530 N. At this load the footing was translated horizontally. The figure shows that as the footing translates horizontally the relevant horizontal load traces a path around a yield surface. In this particular test the translation was u_2 so the only horizontal load developed was H_2 . It is instructive to observe that the other load components are all relatively unaffected by the translation, as was expected. It is also possible to carry out tests involving translations $u_2, u_3, -u_2$ and $-u_3$. The results of these translations are shown in Figure 10 where the load paths for H_2 and H_3 are plotted. Note that each of the tests starts at a different vertical load. However, it is clear that the magnitudes and the shapes of the load paths are similar for the different translations. This confirms the expectation that similar load paths will be traced out regardless of the translation direction. Similar experiments were carried out for rotations and twists with the same results (i.e. the results were independent of direction).

The data, such as shown in Figure 10, can be easily compared by normalising all the loads by V_0 as suggested in equation 2. Results are plotted in Figure 11 for all possible pure horizontal, rotational and twisting swipes with the negative swipes reflected about the

Table 1. Parameter values for work-hardening model.

Parameter	This study	Gottardi et al. 1999	Byrne & Houlsby 2001
h_o	0.122	0.122	0.154
m_o	0.077	0.090	0.094
q_o	0.033	N/A	N/A
β_1	0.688	1.0	0.82
β_2	0.709	1.0	0.82
a	-0.212	-0.223	-0.25

vertical load axis. It is clear that the results depend on the mode (i.e. translation/twisting/rotation) of the swipe test but not on the direction. Equation 2 can be fitted to the above results to give the parameter values in Table 1, which are compared to data for footings on sand under planar loading.

In determining these parameters it was also necessary to use results for combined swipes, that is swipes involving simultaneous rotation and translation and other combinations of movements. For instance Figure 12 shows the results from a test where a translation of u_3 and rotation of $-\theta_3$ were applied simultaneously to the foundation. A number of these tests (twenty included in the above analysis) were performed as they are necessary in determining the fit, and in particular determining

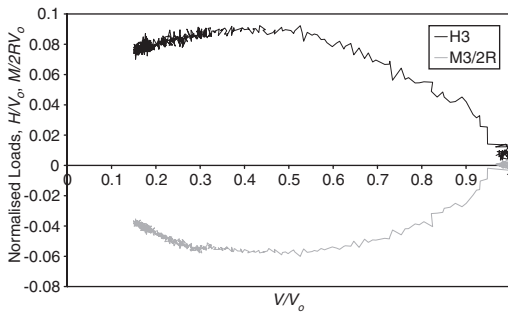

Figure 12. Non co-planar loading applied to the foundation.

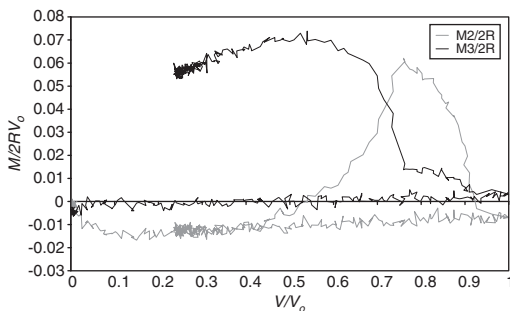

Figure 13. A swipe test where consecutive rotations are performed.

the parameter a which gives the rotation of the ellipse in the $h:m$ plane. The test shown in Figure 12 could not have been performed using the previous 3dof loading rig as it involves non co-planar loads. Equally Figure 13 shows a test unique to the 6dof device in that during the swipe test the footing was first rotated by θ_2 and then rotated by θ_3 . (i.e. orthogonal and consecutive rotations). Initially under the rotation θ_2 the load path for M_2 tracks around a yield surface. When θ_2 stops and θ_3 starts the response for M_2 drops off and the response for M_3 picks up and eventually tracks around the same yield surface that M_2 tracked.

4 CONCLUSIONS

In this paper the description of a unique loading device capable of applying six degree-of-freedom motion to a model foundation is presented. The resulting loads on the foundation are measured using a six degree-of-freedom load cell. A number of experiments, mainly displacement controlled swipe tests, are presented and interpreted to provide verification of the extension of a three degree-of-freedom plasticity model to six degrees-of-freedom. Further experimental work is required to verify the model fully.

ACKNOWLEDGEMENTS

The authors acknowledge the funding from the Lubbock Trustees (pilot project grant), the Royal Society (equipment grant), the Department of Engineering Science at Oxford University and EPSRC. We acknowledge the work of Clive Baker in constructing the 6dof load cell and Chris Waddup who made the actuator frame and LVDT support frame. We also acknowledge the work carried out by final year undergraduate project students: Llywelyn ap Gwilym, Ed Stiles and Rachel Williams. The experimental work described here was conducted by these students under the direction of BWB.

REFERENCES

- ap Gwilym, T.L.I. ab E. 2004. *Control of a six degree of freedom loading rig*. Fourth year project report, Department of Engineering Science, University of Oxford.
- Butterfield, R., Houlsby, G.T. and Gottardi, G. 1997. Standardised sign conventions and notation for generally loaded foundations. *Géotechnique* 47, N° 5, pp 1051–1054; corrigendum *Géotechnique* 48, N° 1, p 157.
- Byrne, B.W. and Houlsby, G.T. 2001. Observations of footing behaviour on loose carbonate sands. *Géotechnique* 51, N° 5, pp 463–466.
- Byrne, B.W. and Houlsby, G.T. 2003. Foundations for offshore wind turbines. *Phil. Trans. Roy. Soc. A* 361, Dec., pp 2909–2930.
- Byrne, B.W., Houlsby, G.T., Martin, C.M. and Fish, P.M. 2002. Suction caisson foundations for offshore wind turbines. *Wind Engineering* 26, No 3.
- Cassidy, M.J., Byrne, B.W. and Houlsby, G.T. 2002. Modelling the behaviour of a circular footing under combined loading on loose carbonate sand. *Géotechnique* 52, N° 10, pp 705–712.
- Gottardi, G., Houlsby, G.T. and Butterfield, R. 1999. The plastic response of circular footings on sand under general planar loading. *Géotechnique* 49, N° 4, pp 453–470.
- Houlsby, G.T. and Cassidy, M.J. 2002. A plasticity model for the behaviour of footings on sand under combined loading. *Géotechnique* 52, N° 2, pp 117–129.
- Martin, C.M. 1994. *Physical and numerical modelling of offshore foundations under combined loads*. DPhil Thesis, University of Oxford.
- Martin, C.M. and Houlsby, G.T. 2000. Combined loading of spudcan foundations on clay: laboratory tests. *Géotechnique* 50, N° 4, pp 325–338.
- Martin, C.M. and Houlsby, G.T. 2001. Combined loading of spudcan foundations on clay: numerical modelling. *Géotechnique* 51, N° 8, pp 687–700.
- Stewart, D. 1965. A platform with six degrees of freedom. *The Institution of Mechanical Engineers* 180, N° 15, pp 371–384.
- Stiles, E. 2004. *Experiments using a six degree of freedom loading rig*. Fourth year project report, Department of Engineering Science, University of Oxford.
- Williams, R. 2005. *Six degree of freedom loading tests on sand and clay*. Fourth year project report, Department of Engineering Science, University of Oxford, in preparation.